



- **Non polarized, non-latching hermetically sealed relay**

Relais hermétique monostable non polarisé

• Contact arrangement <i>Combinaison des contacts</i>	2 PDT 2 RT
• Coil supply <i>Alimentation bobine</i>	Direct current <i>Courant continu</i>
• Qualified or in accordance with <i>Qualifié selon ou en accord avec</i>	CECC16101-014 CECC16101-021 MIL-PRF-39016/6 YA-14 / YA-15

- **Available in Hi-REL quality**

Disponible en version Hi-REL (haute fiabilité)

PRINCIPAL TECHNICAL CHARACTERISTICS
CARACTERISTIQUES TECHNIQUES PRINCIPALES

• Contacts rated at <i>Prévu pour commuter</i>	2 Amps / 28 Vdc 2 A / 28 Vcc
• Weight <i>Masse</i>	11 g max
• Dimensions of case <i>Dimensions du boîtier</i>	20,6 x 10,4 x 10,5 mm max
• Balanced armature design, all welded construction <i>Armature balancée, construction soudée</i>	
• Hermetically sealed, corrosion protected metal can <i>Boîtier métallique hermétique protégé anti-corrosion</i>	
• Special models available upon request <i>Modèles spécifiques sur demande</i>	

Application notes:

001
007

Applicable sockets:

HRCW
S250

Accessories:

10106 Spacer pad

CONTACT ELECTRICAL CHARACTERISTICS / CONTACT RATING
CARACTERISTIQUES ELECTRIQUES DES CONTACTS / POUVOIR DE COMMUTATION

Minimum operating cycles <i>Durée de vie minimale</i>	Type of load <i>Type de charge</i>	28 Vdc	115Vac/60-400Hz
100 000 cycles	Resistive load <i>charge résistive</i>	2A	0.3A
20 000 cycles	Inductive load <i>charge inductive (L/R=5ms)</i>	0.75A	-
100 000 cycles	Lamp load <i>charge lampe (inrush 12 In)</i>	0.16A	-
50 cycles	Resistive overload <i>surcharge résistive</i>	4A	-
400 000 cycles	At 25% rated resistive load <i>à 25% de la charge nominale résistive</i>		
500 000 cycles	Low level / <i>bas niveau</i>	30µA / 30mV	

AMERICAS.

Tel: +1 714-736-7599
<http://www.esterline.com/powersystems>

EUROPE.

Tel: +33 3 87 97 31 01
Fax: +33 3 87 97 96 86

ASIA

Tel: +852 2 191 3830
Fax: +852 2 389 5803

COIL CHARACTERISTICS (Vdc)
CARACTERISTIQUES DES BOBINES (Vcc)

F250-15 CODE	G	C	C	B	B	A	A	D	E
F250-14 CODE	G	C	C	B	B	A	A	D	E
CECC 16101-014 CODE	01	02	06	11	13	20	21	24	24
Nominal operating voltage <i>Tension nominale (Un)</i>	5	6	6	12	12	28	28	36	48
Maximum operating voltage at +125°C <i>Tension maximale à +125°C</i>	6	7.5	7.5	15	15	32	32	42	55
Maximum pickup voltage at +25° C (Cold coil) <i>Tension d'enclenchement assuré à +25° C (Bobine froide)</i>	2.7	3.2	3.5	6.4	7	13.5	14.5	17.0	28
Maximum pickup voltage at +125° C (Cold coil) <i>Tension d'enclenchement assuré à +125° C (Bobine froide)</i>	3.8	4.5	4.5	9	9	18	19	24	36
Maximum drop-out voltage at +125°C <i>Tension de déclenchement assuré à +125°C</i>	2.4	2.9	2.9	5.8	5.8	12	12	16	23
Minimum drop-out voltage at -65°C <i>Tension de déclenchement assuré à -65°C</i>	0.21	0.25	0.25	0.5	0.5	1.0	1.0	1.8	2.0
Coil resistance in $\Omega \pm 10\%$ at +25°C <i>Résistance de la bobine en $\Omega \pm 10\%$ à +25° C</i>	27	37	47.5	150	190	700	935	1250	2600

BS CECC 16101-021 CODE	01	03	05	06	07	08	09	14	15
Nominal operating voltage <i>Tension nominale (Un)</i>	6	6	12	12	24	24	24	24	20
Maximum operating voltage at +125°C <i>Tension maximale à +125°C</i>	7.2	7.2	14.4	14.4	32	32	32	32	24
Maximum pickup voltage at +25° C (Cold coil) <i>Tension d'enclenchement assuré à +25° C (Bobine froide)</i>	3.6	3.6	7.2	7.2	14.4	14.4	14.4	14.4	10.6
Minimum drop-out voltage at 25°C <i>Tension de déclenchement assuré à 25°C</i>	0.3	0.3	0.6	0.6	1.2	1.2	1.2	1.2	1.0
Coil resistance in $\Omega \pm 10\%$ at +25°C <i>Résistance de la bobine en $\Omega \pm 10\%$ à +25° C</i>	40	60	210	320	675	830	1250	700	700

GENERAL CHARACTERISTICS
CARACTERISTIQUES GENERALES

Temperature range / Gamme de temperature	-65°C à +125°C
Dielectric strength at sea level / Rigidité diélectrique au niveau de la mer - All circuits to ground and circuit to circuit / Entre contacts et masse et entre les contacts - Coil to ground and across open contacts / Entre bobine et masse et entre contacts ouverts	1000 Vrms / 50 Hz 500 Vrms / 50 Hz
Dielectric strength at altitude 25.000 m (all points) <i>Rigidité diélectrique à 25 000 m (tous points)</i>	350 Vrms / 50Hz)
Initial insulation resistance at 100 Vdc / Résistance d'isolement initiale sous 100 Vcc	1 000 M Ω min.
Sinusoidal vibration / Vibrations sinusoïdales	3 mm DA / 10 - 70 Hz 30 G / 70 - 3000 Hz
Random vibration / Vibration aléatoire	0,4g ² /Hz 50-2000Hz
Mechanical shock / Chocs mécaniques	100 G / 11 ms
Maximum contact opening time under vibration and shock <i>Durée maximum d'ouverture des contacts sous l'influence des vibrations et chocs</i>	10 μ sec
Operate time at nominal voltage / Temps d'enclenchement sous tension nominale	4 ms max
Release time / Temps de déclenchement	4 ms max
Bounce time / Temps de rebonds	2.5 ms max
Contact resistance ar rated current <i>Résistance de contact sous courant nominal</i>	50 m Ω max

MOUNTING STYLES
TYPES DE FIXATIONS

Dimensions in mm
Tolerances, unless otherwise specified, ±0.25mm

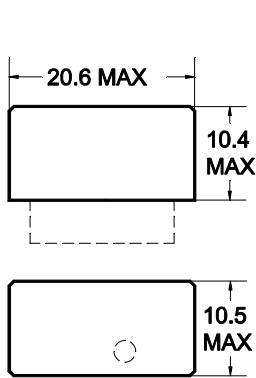

CODE FOR CECC : 01
CODE FOR CECC021 : 01
CODE FOR F250-14: 1
CODE FOR F250-15: 1

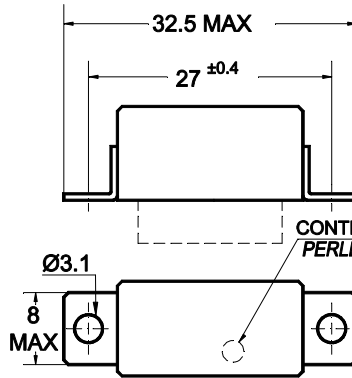

CODE FOR CECC : 05
CODE FOR CECC021 : 04
CODE FOR F250-14: 7

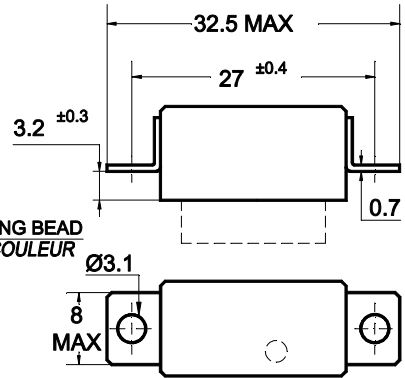

CODE FOR CECC : 04
CODE FOR CECC021 : 05
CODE FOR F250-14: 2
CODE FOR F250-15: 7

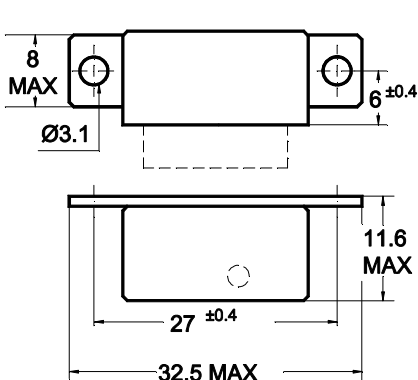

CODE FOR CECC : 14
CODE FOR CECC021: 03
CODE FOR F250-14: 4
CODE FOR F250-15: 4

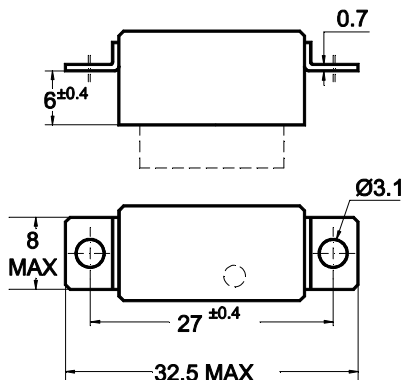

CODE FOR CECC : 03
CODE FOR F250-14: 3
CODE FOR F250-15: 2

TERMINAL TYPES
TYPES DE SORTIES

CODE FOR CECC : 02
CODE FOR CECC021: 12
CODE FOR F250-14: 1
CODE FOR F250-15: 1

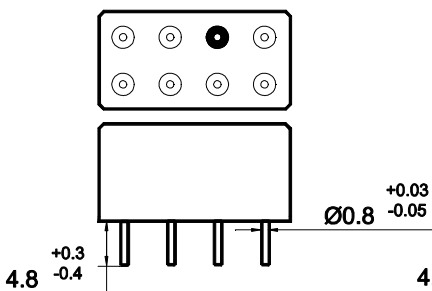

TIN PLATED PINS (8)
SORTIE ETAMEES

CODE FOR CECC : 01
CODE FOR CECC021: 11
CODE FOR F250-14: 2
CODE FOR F250-15: 2

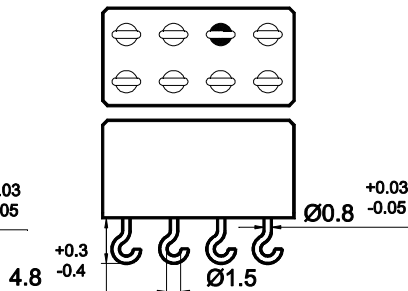

SOLDER HOOKS
CROCHETS ETAMES

CODE FOR F250-14: 4
CODE FOR F250-15: 4

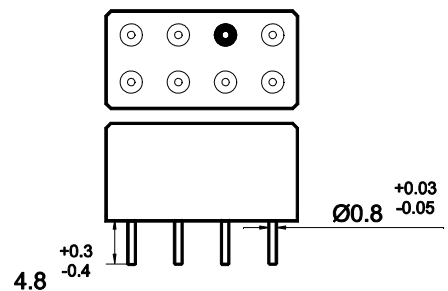

GOLD PLATED PINS
SORTIES DOREES

SCHEMATIC DIAGRAM

SCHEMAS

BOTTOM VIEW, DE-ENERGIZED COIL
VUE DE DESSOUS, BOBINE NON ALIMENTEE

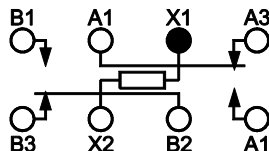

TERMINAL DESIGNATIONS ARE FOR REFERENCE ONLY
AND DO NOT APPEAR ON STANDARD UNITS
LE REPERAGE DES SORTIES N'EST PAS REPRIS SUR LE RELAIS

NUMBERING SYSTEM

SYSTEME DE REFERENCES

CODE F250-14/15:

F250-14/15 X X X XXX

Basic series designation | Référence de base

1. Terminal type | Type de sortie
2. Mounting style | Type de fixation
3. Coil code | Code bobine
4. See note 5 | Voir remarque 5

CODE CECC 16101014:

CECC 16101-014 XX XX XX

Basic series designation | Référence de base

1. Coil code | Code bobine
2. Mounting style | Type de fixation
3. Terminal type | Type de sortie

CODE CECC 16101021:

F250 XX XX XX XX

Basic series designation | Référence de base

1. See note 7 | Voir remarque 7
2. Coil code | Code bobine
3. Mounting style | Type de fixation
4. Terminal type | Type de sortie

NOTES

REMARQUES

1. Socket:
 - 1.1 HRCW with mounting hardware and solder connections for wires.
 - 1.2 S250 with mounting hardware and crimping contacts.
 - 1.3 SF250CE32E solder PCB

Socles:

 - 1.1 HRCW avec système de montage et fûts à souder.
 - 1.2 S250 avec système de montage et contacts à sertir.
 - 1.3 SF250CE32E à souder sur PCB
2. Isolation spacer 10106 pads for PCB mounting available on request.
Possibilité de cales isolantes 10106 pour montage PCB.
3. For other mounting styles or terminal types, please contact the factory
Autres fixations ou sorties sont disponibles : nous consulter.
4. Ultrasonic cleaning may adversely effective the normally closed contacts
Le lavage aux ultrasons peut dans certains cas provoquer une altération des contacts repos.
5. Qualification and quality levels : Contact the factory
Niveaux de qualification et de qualité : Nous consulter.
6. Coil time constant L/R : 1.5ms
Constante de temps L/R des bobines : 1.5ms
7. Contact variant : 01 : standard, 02 : with low level capacity 10mA (50Ω Max)
Code contact: 01 standard / 02 avec capacité bas niveau 10mA (50ΩMax)
8. Short pin terminals available. Contact the factory
Sortie courte disponible. Nous consulter