

MFL Single and Dual DC-DC Converters

28 VOLT INPUT - 65 WATT

FEATURES

- Parallel up to 3 converters—maximum recommended power is 70% of the total available power.
- Operating temperature -55 °C to +125 °C
- Qualified to MIL-PRF-38534 Class H
- Input voltage range 16 to 40 volts
- Transient protection up to 80 volts for 50 ms
 - Converter will shut down at an input voltage above approximately 45 volts
- Fully isolated, magnetic feedback
- Fixed high switching frequency
- Remote sense and output trim on single output models
- Primary and secondary inhibit function
- Synchronization input and output
- Indefinite short circuit protection
- High power density with up to 85% efficiency



MODELS	
OUTPUT VOLTAGE (V)	
SINGLE	DUAL
3.3	±5
5	±12
12	±15
15	
28	

DESCRIPTION

The Interpoint® MFL Series™ of DC-DC converters offers up to 65 watts of power in a low profile package. The MFL converters are manufactured in our fully certified and qualified MIL-PRF-38534 Class H production facility and packaged in hermetically sealed steel cases. They are ideal for use in programs requiring high reliability, small size, and high efficiency. They operate over a -55 °C to +125 °C temperature range with a 28 V nominal input. On dual output models, up to 70% of the rated output power can be drawn from either the positive or negative outputs. The welded, hermetically sealed package is 3.005 x 1.505 x 0.400 inches.

SCREENING

MFL converters are offered with standard screening, “ES” or fully compliant to MIL-PRF-38534 Class H screening. See Table 9 on page 13 and Table 10 on page 14 for more information.

DESIGN FEATURES

The MFL Series converters are switching regulators that use a quasi-square wave, single ended forward converter design with a constant switching frequency of 600 kHz, typical.

Isolation between input and output circuits is provided with a transformer in the forward path and wide bandwidth magnetic coupling in the feedback control loop. The MFL Series uses a unique dual loop feedback technique that controls output current with an inner feedback loop and output voltage with a cascaded voltage mode feedback loop.

The additional secondary current mode feedback loop improves transient response in a manner similar to primary current mode control and allows for ease of paralleling.

Tight load regulation is achieved through a wide-bandwidth magnetic feedback circuit.

INHIBIT

The MFL Series converters have two inhibit terminals (INH1 and INH2) that can be used to disable power conversion, resulting in a very low quiescent input current. See Table 5 on page 6 for specifications.

SYNC

Converters may be synced to an external clock (525 to 675 kHz) or to one another by using the sync in or out pins. See Table 5 on page 6 for specifications.

MFL Single and Dual DC-DC Converters

28 VOLT INPUT - 65 WATT

SENSE AND TRIM

Single output models provide sense to maintain voltage at the load. The converters output voltage can also be trimmed up. See Figure 1.

The units designated as slaves have the MSTR/INH2 pin (pin 12) connected to the SNS RTN pin (pin 9) of the master unit. Figure 2 on page 3 shows the typical setup for two or three units in parallel.

CURRENT SHARING AND PARALLEL OPERATION

For increased power parallel up to 3 converters. The maximum recommended power is 70% of the total available power. Multiple MFL converters may be used in parallel to drive a common load. Only single output models with SENSE and SNS RTN can be used in the share mode. In this mode of operation the load current is shared by two or three MFL converters.

A second slave unit may be placed in parallel with a master and slave; this requires the TRI pin (pin 3) of the master unit to be connected to the SNS RTN pins (pin 9), per Figure 2 on page 3.

In current sharing mode, the converters function as a current source. For this reason it is important that their outputs be connected to the common ground at all times to prevent an excessively high voltage at their outputs.

In current sharing mode, one MFL converter is designated as a master. The SLAVE pin (pin 11) of the master is left unconnected and the MSTR/INH2 pin (pin 12) of the master is connected to the SLAVE pin (pin 11) of the slave units.

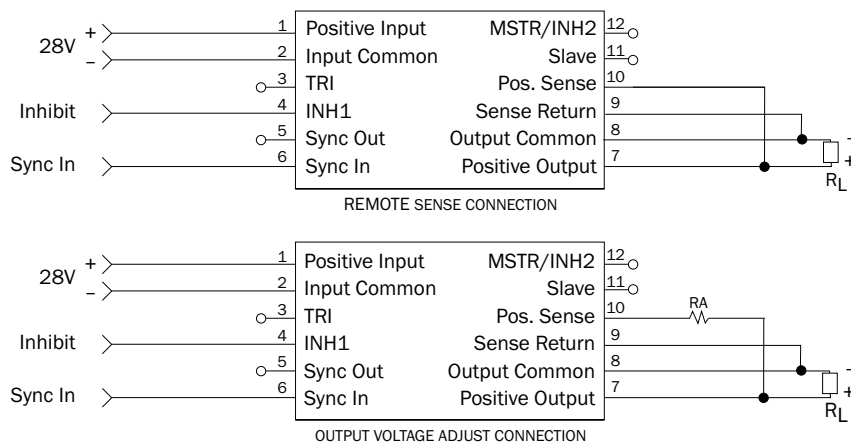

V _{OUT} INCREASE VOLTS	R _A (Ω)			
	3.3 V	5 V	12 V	15 V
0.1	66	77	27	21
0.2	131	153	55	43
0.3	196	230	82	64
0.4	262	307	109	86
0.5	349	396	139	109

- Notes
- When using remote sense for voltage compensation or when using remote sense for trim, the output will drift over temperature. Contact Applications Engineering for more information powerapps@craneae.com.
 - Do not exceed the maximum rated power.

FIGURE 1: SENSE CONNECTIONS AND TRIM TABLE – SINGLE OUTPUT MODELS

MFL Single and Dual DC-DC Converters

28 VOLT INPUT - 65 WATT

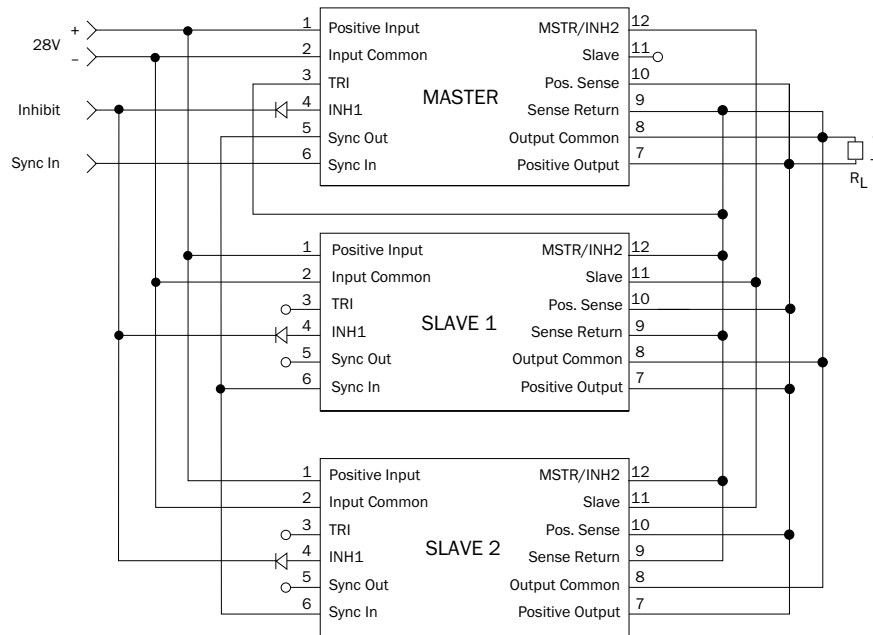

CONNECT TRIPLE (TRI) ONLY WHEN 2 SLAVES ARE USED

Notes

1. No one converter may carry more than its maximum rated current.
2. Individual converter operation, load and layout may affect the actual current shared. Contact Applications Engineering for more information at powerapps@craneae.com.
3. When paralleling SMFLs a diode is required at the input of each inhibit pin as SMFLs do not have an internal diode on the inhibit pin.

FIGURE 2: PARALLEL CONNECTIONS – SINGLE OUTPUT MODELS

MFL Single and Dual DC-DC Converters

28 VOLT INPUT - 65 WATT

PIN OUT			
Pin	Single Output	MFL2828S only	Dual Output
1	Positive Input	Positive Input	Positive Input
2	Input Common	Input Common	Input Common
3	Triple (TRI)	Triple (TRI)	Triple (TRI)
4	Inhibit 1 (INH1)	Inhibit 1 (INH1)	Inhibit 1 (INH1)
5	Sync Out	Sync Out	Sync Out
6	Sync In	Sync In	Sync In
7	Positive Output	Positive Output	Positive Output
8	Output Common	No connection	Output Common
9	Sense Return	Output Common	Negative Output
10	Positive Sense	No connection	No connection
11	Slave	Slave	Slave
12	Master/Inhibit 2 (MSTR/INH2)	Master/Inhibit 2 (MSTR/INH2)	Master/Inhibit 2 (MSTR/INH2)

TABLE 1: PIN OUT

PINS NOT IN USE	
TRI	Leave unconnected
Inhibit 1 (INH1)	Leave unconnected
Sync Out	Leave unconnected
Sync In	Connect to Input Common
Sense Return	Connect to Output Common
Positive Sense	Connect to Positive Output
Slave	Leave unconnected
Master/Inhibit 2 (MSTR/INH2)	Leave unconnected

TABLE 2: PINS NOT IN USE

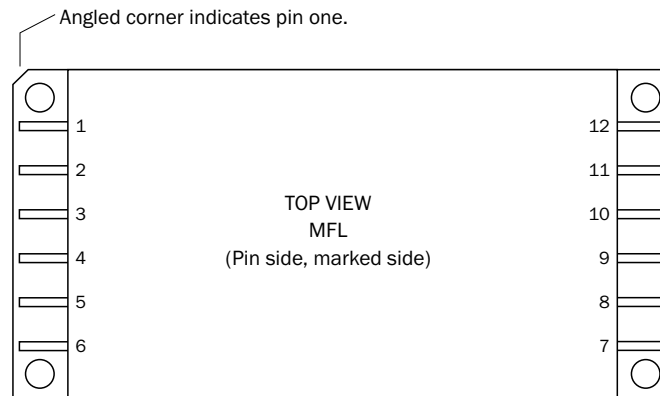

See Figure 17 on page 12 for dimensions

FIGURE 3: PIN OUT

MFL Single and Dual DC-DC Converters

28 VOLT INPUT - 65 WATT

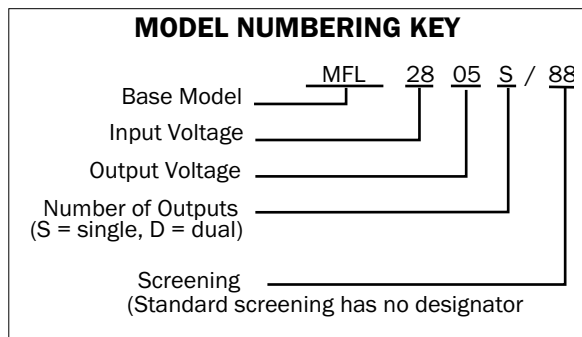

FIGURE 4: MODEL NUMBERING KEY

SMD NUMBERS	
STANDARD MICROCIRCUIT DRAWING (SMD)	MFL SERIES SIMILAR PART
5962-0621301HXC	MFL283R3S/883
5962-9316301HXC	MFL2805S/883
5962-9316201HXC	MFL2812S/883
5962-9316101HXC	MFL2815S/883
5962-9319101HXC	MFL2805D/883
5962-9319201HXC	MFL2812D/883
5962-9319301HXC	MFL2815D/883

The SMD number shown is for Class H screening. For exact specifications for an SMD product, refer to the SMD drawing. SMDs can be downloaded from <https://landandmaritimeapps.dla.mil/programs/smcr>

TABLE 3: SMD NUMBER CROSS REFERENCE

MODEL NUMBER OPTIONS				
TO DETERMINE THE MODEL NUMBER ENTER ONE OPTION FROM EACH CATEGORY IN THE FORM BELOW.				
CATEGORY	Base Model and Input Voltage	Output Voltage ¹	Number of Outputs ²	Screening ³
OPTIONS	MFL28	3R3, 05, 12, 15, 28	S	(standard, leave blank)
		05, 12, 15	D	ES 883
FILL IN FOR MODEL # ⁴	MFL28	_____	_____ / _____	

Notes

- Output Voltage: An R indicates a decimal point. 3R3 is 3.3 volts out. The value of 3R3 is only available in single output models.
- Number of Outputs: S is a single output and D is a dual output.
- Screening: For standard screening leave the screening option blank. For other screening options, insert the desired screening level. For more information see Table 9 on page 13 and Table 10 on page 14. MFL2828S is not available on an SMD.
- If ordering by model number add a "Q" to request solder dipped leads (MFL2805S/883-Q).

TABLE 4: MODEL NUMBER OPTIONS

MFL Single and Dual DC-DC Converters

28 VOLT INPUT - 65 WATT

TABLE 5: OPERATING CONDITIONS, ALL MODELS, 25°C CASE, 28 VIN, 100% LOAD, UNLESS OTHERWISE SPECIFIED.

PARAMETER	CONDITIONS	ALL MODELS			UNITS
		MIN	TYP	MAX	
LEAD SOLDERING TEMPERATURE ¹	10 SECONDS MAX.	—	—	300	°C
STORAGE TEMPERATURE ¹		-65	—	+150	°C
CASE OPERATING TEMPERATURE	FULL POWER	-55	—	+125	°C
	ABSOLUTE ¹	-55	—	+135	
DERATING OUTPUT POWER/CURRENT ¹	LINEARLY	From 100% at 125°C to 0% at 135°C			
ISOLATION: INPUT TO OUTPUT, INPUT TO CASE, OUTPUT TO CASE ²	@ 500 VDC AT 25°C	100	—	—	Megohms
INPUT TO OUTPUT CAPACITANCE ¹		—	150	—	pF
UNDERVOLTAGE LOCKOUT ¹ -55°C TO +125°C	RISING V _{IN} (TURN ON)	14.4	—	16.0	V
	FALLING V _{IN} (TURN OFF)	11.5	—	14.1	
CURRENT LIMIT ³	% OF FULL LOAD	—	125	—	%
AUDIO REJECTION ¹		—	50	—	dB
SWITCHING FREQUENCY	-55°C TO +125°C	525	600	675	kHz
SYNCHRONIZATION IN -55°C TO +125°C	INPUT FREQUENCY	525	—	675	kHz
	DUTY CYCLE ¹	40	—	60	%
	ACTIVE LOW	—	—	0.8	V
	ACTIVE HIGH ¹	4.5	—	5.0	
	REFERENCED TO	INPUT COMMON			
	IF NOT USED	CONNECT TO INPUT COMMON			
SYNCHRONIZATION OUT	REFERENCED TO	INPUT COMMON			
	IF NOT USED	LEAVE UNCONNECTED			
INHIBIT 1 ACTIVE LOW (OUTPUT DISABLED) Do not apply a voltage to the inhibit pin. ⁴	INHIBIT PIN PULLED LOW	—	—	0.8	V
	INHIBIT PIN SOURCE CURRENT ¹	—	—	10	mA
	REFERENCED TO	INPUT COMMON			
INHIBIT 1 ACTIVE HIGH (OUTPUT ENABLED) Do not apply a voltage to the inhibit pin. ⁴	INHIBIT PIN CONDITION	OPEN COLLECTOR OR UNCONNECTED			
	OPEN INHIBIT PIN VOLTAGE ¹	9	—	12	V
INHIBIT 2 ACTIVE LOW (OUTPUT DISABLED) Do not apply a voltage to the inhibit pin. ⁴	INHIBIT PIN PULLED LOW	—	—	0.5	V
	INHIBIT PIN SOURCE CURRENT ¹	—	—	5	mA
	REFERENCED TO	OUTPUT COMMON			
INHIBIT 2 ACTIVE HIGH (OUTPUT ENABLED) Do not apply a voltage to the inhibit pin. ⁴	INHIBIT PIN CONDITION	OPEN COLLECTOR OR UNCONNECTED			
	OPEN INHIBIT PIN VOLTAGE ¹	—	—	9	V

For mean time between failures (MTBF) contact Applications Engineering at powerapps@cranae.com or call +1 425.882.3100.

Notes

1. Guaranteed by characterization test and/or analysis. Not a production test.
2. When testing isolation, input pins are tied together and output pins are tied together. They are tested against each other and against case. Discharge the pins before and after testing.
3. Dual outputs: The over-current limit will trigger when the sum of the currents from both outputs reaches 125% (typical value) of the maximum rated "total" current of both outputs.
4. An external inhibit interface should be used to pull the inhibits low or leave them floating. The inhibit pins can be left unconnected if not used.

MFL Single and Dual DC-DC Converters

28 VOLT INPUT - 65 WATT

TABLE 6: ELECTRICAL CHARACTERISTICS: -55 °C TO +125 °C CASE, 28 VIN, 100% LOAD, UNLESS OTHERWISE SPECIFIED.

SINGLE OUTPUT MODELS		MFL283R3S			MFL2805S			MFL2812S			UNITS
PARAMETER	CONDITIONS	MIN	TYP	MAX	MIN	TYP	MAX	MIN	TYP	MAX	
OUTPUT VOLTAGE		3.21	3.30	3.39	4.87	5.00	5.13	11.76	12.00	12.24	V
OUTPUT CURRENT	$V_{IN} = 16$ to 40 V	0	—	12.12	0	—	10	0	—	5	A
OUTPUT POWER	$V_{IN} = 16$ to 40 V	0	—	40	0	—	50	0	—	60	W
OUTPUT RIPPLE	$T_C = 25^\circ\text{C}$	—	10	35	—	15	35	—	30	75	mV p-p
10 KHZ - 2 MHZ	$T_C = -55^\circ\text{C}$ TO $+125^\circ\text{C}$	—	10	50	—	30	50	—	45	100	
LINE REGULATION	$V_{IN} = 16$ to 40 V	—	0	20	—	0	20	—	0	20	mV
LOAD REGULATION	NO LOAD TO FULL	—	—	40	—	—	20	—	—	20	mV
INPUT VOLTAGE	CONTINUOUS	16	28	40	16	28	40	16	28	40	V
NO LOAD TO FULL	TRANSIENT 50 ms ^{1, 2}	—	—	80	—	—	80	—	—	80	V
INPUT CURRENT	NO LOAD	—	70	100	—	70	120	—	50	100	mA
	INHIBITED-INH1	—	9	14	—	9	14	—	9	14	
	INHIBITED-INH2	—	35	70	—	35	70	—	35	70	
INPUT RIPPLE CURRENT	10 kHz - 10 MHz	—	15	50	—	15	50	—	15	50	mA p-p
EFFICIENCY	$T_C = 25^\circ\text{C}$	73	76	—	77	80	—	83	86	—	%
	$T_C = -55^\circ\text{C}$ TO $+125^\circ\text{C}$	71	—	—	75	—	—	81	—	—	
LOAD FAULT ³	POWER DISSIPATION	—	12.5	16	—	12.5	18	—	10	16	W
	RECOVERY ¹	—	1.5	6	—	1.5	4	—	1.5	4	ms
STEP LOAD RESPONSE ^{3, 4}	TRANSIENT	—	200	±300	—	250	±350	—	450	±600	mV pk
50% - 100% - 50%	RECOVERY ¹	—	1.5	3.0	—	1.5	3.0	—	1.5	3.0	ms
STEP LINE RESPONSE ^{1, 3, 5}	TRANSIENT	—	250	±300	—	250	±300	—	250	400±	mV pk
16 - 40 - 16	RECOVERY	—	200	300	—	200	300	—	200	300	µs
START-UP ^{3, 6}	DELAY	—	3.5	6	—	3.5	6	—	3.5	6	ms
	OVERSHOOT ¹	—	0	25	—	0	25	—	0	25	mV pk
CAPACITIVE LOAD ^{1, 7}	$T_C = 25^\circ\text{C}$	—	—	1000	—	—	1000	—	—	1000	µF

- Notes
1. Guaranteed by characterization test and/or analysis. Not a production test.
 2. Converter will shut down above approximately 45 volts input but will be undamaged and will restart when voltage drops into normal range.
 3. Recovery time is measured from application of the transient to the point at which V_{OUT} is within 1% of final value.
 4. Step load test is performed at 10 microseconds typical.
 5. Step line characterization test is performed at 100 microseconds ± 20 microseconds.
 6. Tested on release from inhibit.
 7. No affect on dc performance.

MFL Single and Dual DC-DC Converters

28 VOLT INPUT - 65 WATT

TABLE 7: ELECTRICAL CHARACTERISTICS: -55 °C TO +125 °C CASE, 28 VIN, 100% LOAD, UNLESS OTHERWISE SPECIFIED.

SINGLE OUTPUT MODELS		MFL2815S			MFL2828S ²			UNITS
PARAMETER	CONDITIONS	MIN	TYP	MAX	MIN	TYP	MAX	
OUTPUT VOLTAGE		14.55	15.00	15.45	27.16	28.00	28.84	V
OUTPUT CURRENT	V _{IN} = 16 to 40 V	0	—	4.33	0	—	2.32	A
OUTPUT POWER	V _{IN} = 16 to 40 V	0	—	65	0	—	65	W
OUTPUT RIPPLE	T _C = 25 °C	—	30	85	—	100	200	mV p-p
10 KHZ - 2 MHZ	T _C = -55 °C TO +125 °C	—	45	110	—	—	275	
LINE REGULATION ²	V _{IN} = 16 TO 40 V	—	0	20	—	20	60	mV
LOAD REGULATION	NO LOAD TO FULL	—	0	20	—	20	75	mV
INPUT VOLTAGE ²	CONTINUOUS	16	28	40	16 ²	28	40	V
NO LOAD TO FULL	TRANSIENT 50 ms ^{1,3}	—	—	80	—	—	80	V
INPUT CURRENT	NO LOAD	—	50	100	—	60	100	mA
	INHIBITED-INH1	—	9	14	—	9	14	
	INHIBITED-INH2	—	35	70	—	35	70	
INPUT RIPPLE CURRENT	10 kHz - 10 MHz	—	15	50	—	20	50	mA p-p
EFFICIENCY	T _C = 25 °C	84	87	—	83	86	—	%
	T _C = -55 °C TO +125 °C	82	—	—	81	—	—	
LOAD FAULT ³	POWER DISSIPATION	—	10	16	—	7	14	W
	RECOVERY ¹	—	1.5	4	—	1.0	4	ms
STEP LOAD RESPONSE ^{3,4}	TRANSIENT	—	500	±600	—	800	±1400	mV pk
50% - 100% - 50%	RECOVERY ¹	—	1.5	3.0	—	1.5	3.0	ms
STEP LINE RESPONSE ^{1,3,5}	TRANSIENT	—	250	±500	—	250	±800	mV pk
16 - 40 - 16	RECOVERY	—	200	300	—	200	400	µs
START-UP ^{3,6}	DELAY	—	3.5	6	—	3.5	6	ms
	OVERSHOOT ¹	—	0	50	—	0	100	mV pk
CAPACITIVE LOAD ^{1,7}	T _C = 25 °C	—	—	1000	—	—	1000	µF

Notes

1. Guaranteed by characterization test and/or analysis. Not a production test.

2. MFL2828S will operate at 16 volts input but requires 19 volts input to start.

3. Converter will shut down above approximately 45 volts input but will be undamaged and will restart when voltage drops into normal range.

4. Step load test is performed at 10 microseconds typical.

5. Step line characterization test is performed at 100 microseconds ± 20 microseconds.

6. Tested on release from inhibit.

7. No affect on dc performance.

MFL Single and Dual DC-DC Converters

28 VOLT INPUT - 65 WATT

TABLE 8: ELECTRICAL CHARACTERISTICS: -55 °C TO +125 °C CASE, 28 VIN, 100% LOAD, UNLESS OTHERWISE SPECIFIED.

DUAL OUTPUT MODELS		MFL2805D			MFL2812D			MFL2815D			UNITS
PARAMETER	CONDITIONS	MIN	TYP	MAX	MIN	TYP	MAX	MIN	TYP	MAX	
OUTPUT VOLTAGE	+ V _{OUT}	4.85	5.00	5.15	11.64	12.00	12.36	14.55	15.00	15.45	V
	- V _{OUT}	4.82	5.00	5.18	11.58	12.00	12.42	14.47	15.00	15.53	
OUTPUT CURRENT ² V _{IN} = 16 TO 40 V	EITHER OUTPUT	0	±5	7	0	±2.5	3.5	0	±2.16	3.03	A
	TOTAL OUTPUT	0	—	10	0	—	5	0	—	4.34	
OUTPUT POWER ² V _{IN} = 16 to 40 V	EITHER OUTPUT	0	±25	35	0	±30	42	0	±32.5	45.5	W
	TOTAL OUTPUT	—	—	50	—	—	60	—	—	65	
OUTPUT RIPPLE 10 kHz - 2 MHz ± V _{OUT}	T _C = 25 °C	—	—	50	—	—	80	—	—	100	mV p-p
	T _C = -55 °C TO +125 °C	—	50	100	—	50	120	—	50	150	
LINE REGULATION V _{IN} = 16 TO 40 V	+ V _{OUT}	—	0	50	—	0	50	—	0	50	mV
	- V _{OUT}	—	25	100	—	25	100	—	25	100	
LOAD REGULATION NO LOAD TO FULL	+ V _{OUT}	—	0	50	—	10	50	—	10	50	mV
	- V _{OUT}	—	25	100	—	25	120	—	50	150	
CROSS REGULATION T _C = 25 °C	SEE NOTE 3	—	5	8	—	2	4	—	2	4	%
	SEE NOTE 4	—	3	7	—	2	4	—	2	4	
INPUT VOLTAGE NO LOAD TO FULL	CONTINUOUS	16	28	40	16	28	40	16	28	40	V
	TRANSIENT 50 ms ^{1, 5}	—	—	80	—	—	80	—	—	80	V
INPUT CURRENT	NO LOAD	—	50	120	—	50	100	—	50	100	mA
	INHIBITED-INH1	—	9	14	—	9	14	—	9	14	
	INHIBITED-INH2	—	35	70	—	35	70	—	35	70	
INPUT RIPPLE CURRENT	10 kHz - 10 MHz	—	15	50	—	15	50	—	15	50	mA p-p
EFFICIENCY BALANCED LOAD	T _C = 25 °C	77	80	—	83	86	—	84	87	—	%
	T _C = -55 °C TO +125 °C	75	—	—	81	—	—	82	—	—	
LOAD FAULT ⁶	POWER DISSIPATION	—	12.5	18	—	10	16	—	10	16	W
	RECOVERY ¹	—	1.5	4	—	1.5	4	—	1.5	4.0	ms
STEP LOAD RESPONSE ^{6, 7} 50% - 100% - 50% ± V _{OUT}	TRANSIENT	—	250	±350	—	450	±600	—	500	±600	mV pk
	RECOVERY ¹	—	1.5	3.0	—	1.5	3.0	—	1.5	3.0	ms
STEP LINE RESPONSE ^{1, 6, 8} 16 - 40 - 16 V ± V _{OUT}	TRANSIENT	—	250	±300	—	250	±400	—	250	±500	mV pk
	RECOVERY	—	200	300	—	200	300	—	200	300	µs
START-UP ^{6, 9}	DELAY	—	3.5	6	—	3.5	6	—	3.5	6	ms
	OVERSHOOT ¹	—	0	25	—	0	50	—	0	50	mV pk
CAPACITIVE LOAD ^{1, 10, 11}	T _C = 25 °C	—	—	500	—	—	500	—	—	500	µF

Notes

- Guaranteed by characterization test and/or analysis. Not a production test.
- Up to 70% of the total output power is available from either output providing the opposite output is simultaneously carrying 30% of the total power.
- Effect on negative V_{out} from 50%/50% loads to 70%/30% or 30%/70% loads.
- Effect on negative V_{out} from 50%/50% loads to 50% then 10% load on negative V_{out}.
- Converter will shut down above approximately 45 volts input but will be undamaged and will restart when voltage drops into normal range.

- Recovery time is measured from application of the transient to point at which V_{out} is within 1% of final value.
- Step load test is performed at 10 microseconds typical.
- Step line characterization test is performed at 100 microseconds ± 20 microseconds.
- Tested on release from inhibit.
- No affect on dc performance.
- Applies to each output.

MFL Single and Dual DC-DC Converters

28 VOLT INPUT - 65 WATT

TYPICAL PERFORMANCE PLOTS: 25 °C CASE, UNLESS OTHERWISE SPECIFIED.
FOR REFERENCE ONLY. NOT GUARANTEED SPECIFICATIONS.

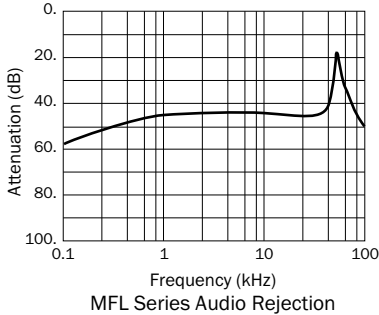

FIGURE 5

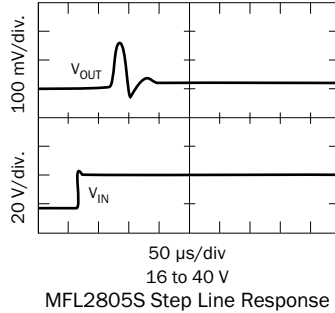

FIGURE 6

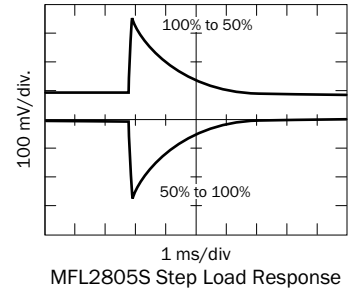

FIGURE 7

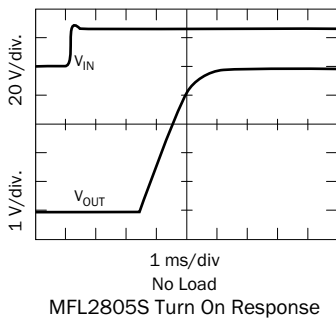

FIGURE 8

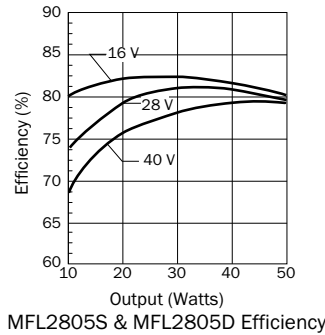

FIGURE 9

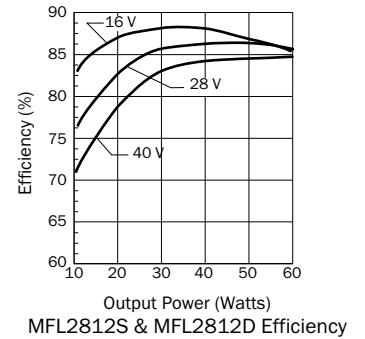

FIGURE 10

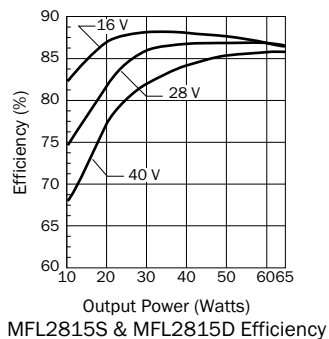

FIGURE 11

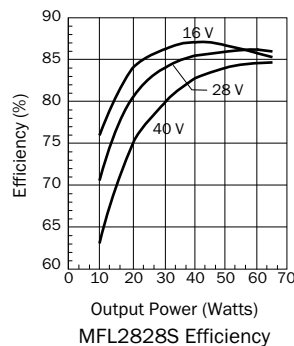

FIGURE 12

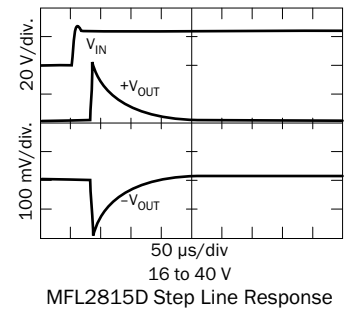

FIGURE 13

MFL Single and Dual DC-DC Converters

28 VOLT INPUT - 65 WATT

TYPICAL PERFORMANCE PLOTS: 25 °C CASE, UNLESS OTHERWISE SPECIFIED.
FOR REFERENCE ONLY. NOT GUARANTEED SPECIFICATIONS.

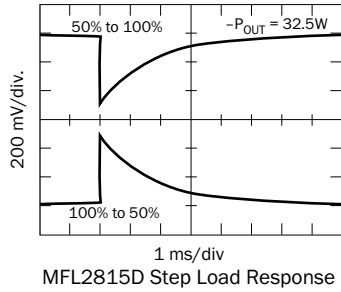

FIGURE 16

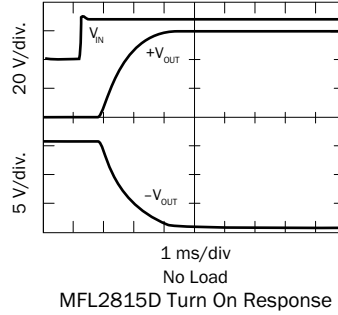

FIGURE 14

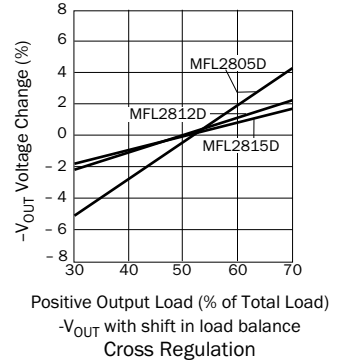

FIGURE 15

MFL Single and Dual DC-DC Converters

28 VOLT INPUT - 65 WATT

TOP VIEW CASE U
Flanged case, short leads

Case "U" does not require an option in the Case Option position of the model number.

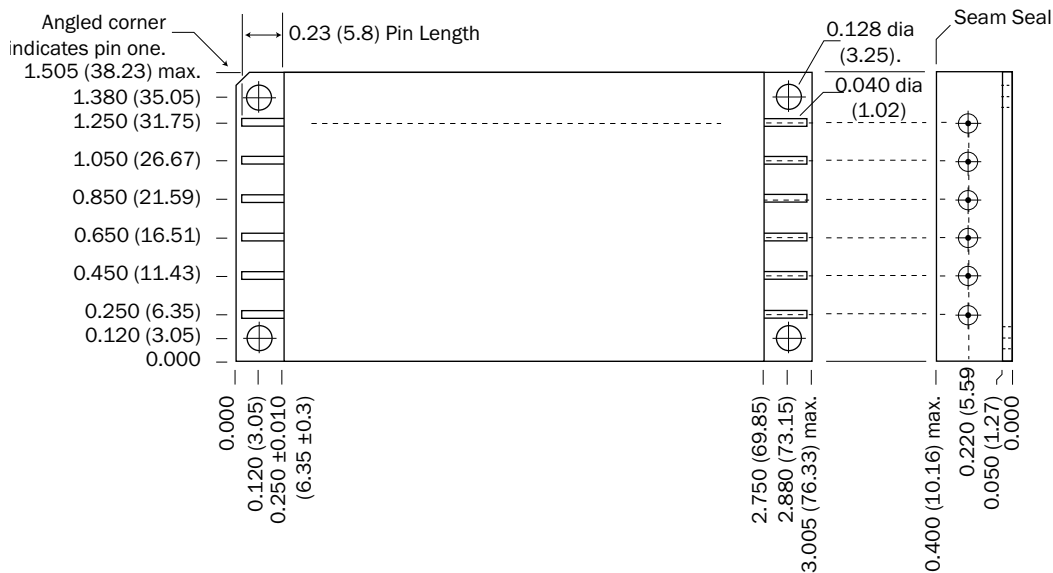

Weight: 86 grams maximum

Case dimensions in inches (mm)
Tolerance ± 0.005 (0.13) for three decimal places
 ± 0.01 (0.3) for two decimal places
unless otherwise specified

CAUTION

Heat from reflow or wave soldering may damage the device. Solder pins individually with heat application not exceeding 300°C for 10 seconds per pin.

Materials

- Header Cold Rolled Steel/Nickel/Gold
- Cover Kovar/Nickel
- Pins #52 alloy/Gold, compression glass seal
Gold plating of 50 - 150 microinches is included in pin diameter
Seal Hole: 0.120 \pm 0.002 (3.05 \pm 0.05)

Please refer to the numerical dimensions for accuracy.

FIGURE 17: CASE U

MFL Single and Dual DC-DC Converters

28 VOLT INPUT - 65 WATT

ELEMENT EVALUATION ¹ HIGH RELIABILITY /883 (CLASS H)

COMPONENT-LEVEL TEST PERFORMED	QML	
	CLASS H /883	
	M/S ²	P ³
Element Electrical	■	■
Visual	■	■
Internal Visual	■	
Final Electrical	■	■
Wire Bond Evaluation	■	■

Notes

1. Element evaluation does not apply to standard and /ES product.
2. M/S = Active components (microcircuit and semiconductor die).
3. P = Passive components, Class H element evaluation. Not applicable to standard and /ES element evaluation.

TABLE 9: ELEMENT EVALUATION

MFL Single and Dual DC-DC Converters

28 VOLT INPUT - 65 WATT

ENVIRONMENTAL SCREENING HIGH RELIABILITY STANDARD, /ES AND /883 (CLASS H)

TEST PERFORMED	NON-QML ¹		CLASS H QML ²
	STANDARD	/ES	/883
Pre-cap Inspection, Method 2017, 2032	■	■	■
Temperature Cycle (10 times)			
Method 1010, Cond. C, -65 °C to +150 °C, ambient			■
Method 1010, Cond. B, -55 °C to +125 °C, ambient		■	
Constant Acceleration			
Method 2001, 3000 g			■
Method 2001, 500 g		■	
PIND, Test Method 2020, Cond. A			■ ³
Burn-in Method 1015, +125 °C case, typical ⁴			
96 hours		■	
160 hours			■
Final Electrical Test, MIL-PRF-38534, Group A,			
Subgroups 1 through 6, -55 °C, +25 °C, +125 °C case			■
Subgroups 1 and 4, +25 °C case	■	■	
Hermeticity Test, Method 1014			
Gross Leak, Cond. C ₁ , fluorocarbon		■	■
Fine Leak, Cond. A ₂ , helium		■	■
Gross Leak, Dip	■		
Final visual inspection, Method 2009	■	■	■

Test methods are referenced to MIL-STD-883 as determined by MIL-PRF-38534.

Notes

1. Non-QML products may not meet all of the requirements of MIL-PRF-38534.
2. All processes are QML qualified and performed by certified operators.
3. Not required by DLA but performed to assure product quality.
4. Burn-in temperature designed to bring the case temperature to +125 °C minimum. Burn-in is a powered test.

TABLE 10: ENVIRONMENTAL SCREENING